

VERTICAL TMR MIXERS

FULL LINE FOR
ALL OPERATIONS



“

Patz is our first TMR and we really like it. Our cows came up 5lbs. per day and the clean up is excellent. We cut our hay cost in half and save ½ hour per day feeding. -Tyler & Mike, MN

”



TRAILER

Pg. 10

270 - 1,580 ft.³ Capacity



STATIONARY

Pg. 26

140 - 1,270 ft.³ Capacity



TRUCK

Pg. 34

420 - 1,270 ft.³ Capacity

Designed for the Professional Producer

RELIABILITY, VERSATILITY, TECHNOLOGY

Patz Vertical Mixers offer mixing capacities from 140-1,580 cu. ft. (11.8-44.7 m³) including single, twin, or triple screw options. The wide selection of sizes, styles, and discharge options make Patz mixers adaptable to every feeding program.



SINCE 1948

For over 70 years, Patz Corporation has been keeping up with changing demands of the Agricultural industry.

We emphasize products that save labor, feed, and fuel by intelligently designed machinery.

IN-HOUSE ENGINEERING

Our experienced Engineering team ensures every machine, part, and option is built-to-print for optimal performance. Over 50 material handling patents show safety and quality are the cornerstone of the Patz brand.

SERVICE & SUPPORT

Every Patz machine has a written 1-year Manufacturing Warranty and 5-year prorated Power Transmission Warranty, a dedicated Product Support team, and local dealerships. Always have access to information with Published Operator's and Parts manuals.



PATENTED TUB MOUNTED MAGNET

This powerful magnet has the strongest pull radius in the industry. The magnet can reach tramp metal in the ration while mixing without restricting feed flow. Metallic items remain secured to the contoured magnet with a 2-stage retention system

This highly recommended feature also comes with a quick-open system. The operator can easily unlatch the magnet to make cleaning and servicing effortless and safe!



PATENTED CONTOURED BAFFLES

The precision height of our patented baffles create space needed inside vertical mixers for ingredients to fall and mix together uniformly.

Our baffles are designed to simulate opposing tapered tub ends while eliminating dead spots in the TMR.



PATENTED RAPTOR™ KNIVES

A forward facing, downward angle design allows knives to dig in and cut bales more aggressively. Ideal for high-hay rations including large round or square bales.

Our Patented Raptor™ knives come in 5 sizes: 4 ¼", 4 ¾", 5 ½", 7 ½", and a massive 10" knife to claw into high density round bale cores.

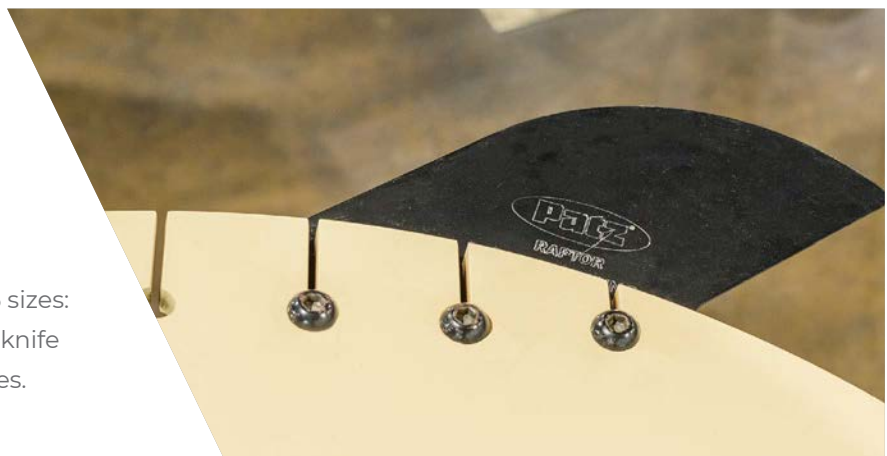

Balanced Flow™ Technology

A *total mixed ration* (TMR) is created when ingredient feed particles fall together simultaneously. A true TMR requires engineering that eliminates obstacles and dead spots without sacrificing mix performance.

Balanced Flow™ Technology creates the Patz signature “rolling boil” with a precision fitted screw inside a vertical relief proportional tub. Feed is processed along the sidewall and pulled away from the tub wall base. Lifting up the screw center, the feed then falls, and mixes at the tub end walls and patented contoured baffles. The Balanced Flow™ created allows the feed to mix uniformly together without crushing ingredients. Restrictor plates separate sidewalls and end walls to adjust the mixing cavity capacity.

Patz Corporation’s Balanced Flow™ Technology ensures a consistent TMR in small and large batches when mixing a wide variety of conventional and alternative ingredients. From long fiber to the finest concentrates, Patz TMR is ***balanced to the last bite.***

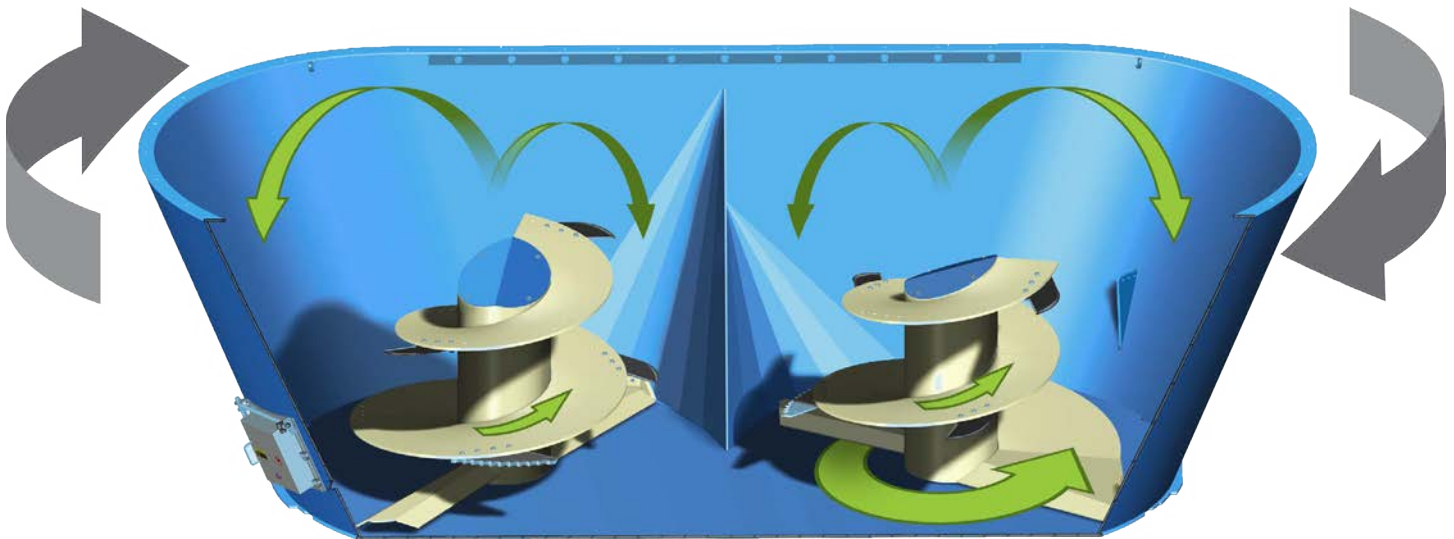

Gray arrows indicate direction of screw rotation.
Green arrows indicate Balanced Flow™ of feed

VORTEX® AND TRU TAPER™ VERTICAL SCREW(S)

Patz vertical mixing screws are constructed of welded steel. AR 400 steel is used in high wear areas such as the leading edge, plow wing, and kicker.

Exclusive to Patz, the Vortex® screw has cupped flighting that helps create the Patz signature “rolling boil” in wide-body tubs ($\geq 96"$ / 2.5m). Designed for narrow profile mixers ($\leq 86"$ / 2.2m wide), the Tru Taper™ screw ensures a consistent mix and superior clean-off for low HP and minimum torque application.

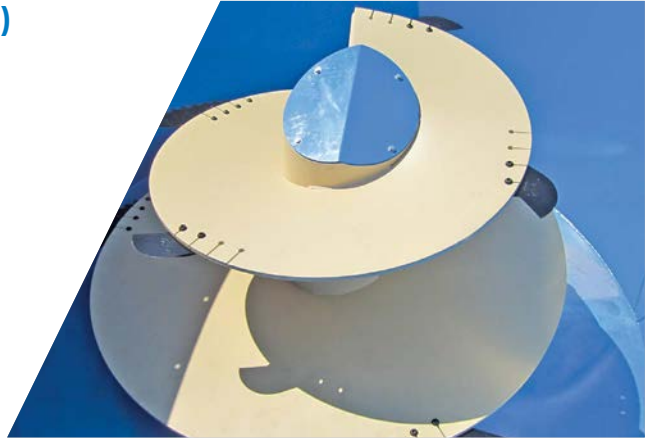

CONE/MULTI-ANGLE TOP

The vertical screw crown diffuses top-loaded material. A cone-top (right) allows easy clean-off in high concentrate rations. A multi-angle top (top right) directs round bales deep into the mixer tub for rapid processing.



OVERLAPPING SIDEWALLS

Sidewalls are made from surface primed UTS 58,000-80,000 PSI steel. Flared tub ends and sidewalls are overlapped and double-joined by an exterior anchor weld and interior seam weld. Seams are overlapped in a clockwise direction like the screw rotation to promote Balanced Flow™, improving upon butt-welded seams.





XH Mixers for XL Workloads

As Dry Matter Intake (DMI) management in dairy and beef herds increases, mixing must adapt to increasingly “hotter” and heavier high-commodity and high-hay rations. Dry hay and feed concentrates - rich in nutrient value - can be abrasive.

Patz Corporation has engineered an Extra Heavy (XH) option to feed today's livestock high density

round bales and balage. Reinforced flooring, thicker side-walls, heavier screws, and a reinforced top ring make XH mixers up to 20% heavier - putting quality steel where you need it most. Upgrade to an XH mixer for longer machine life, heavier rations, and higher trade-in value.



SIDEWALL THICKNESS

The sidewall absorbs tremendous mixing forces. Upgrade to a Patz XH mixer for a $\frac{3}{8}$ " (9.5mm) high-tensile sidewall and baffles compared to the industry standard $\frac{1}{4}$ " (6.4mm).



FLIGHTING THICKNESS

The average screw is lifting 3-4 tons of feed per minute while turning at 20-30 RPM. This may lead to high wear. At $\frac{3}{4}$ " (19mm), Patz XH screws are $\frac{1}{8}$ " thicker than the industry standard.

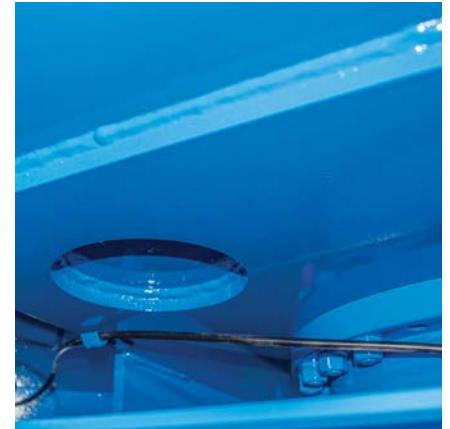

REINFORCED FLOOR

A $\frac{3}{4}$ " (9mm) floorplate is reinforced with thicker subfloor and canitlever steel bracing. Capable of handling round bale processing torques and heavier ration weights.

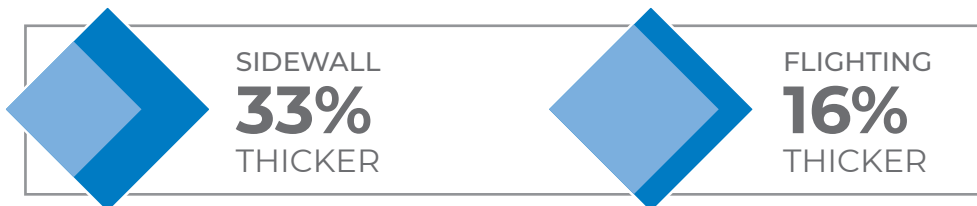

Precision Feeding



AVERY WEIGHT-TRONIX®

INDICATORS

Models: 640, 640XL, 640M, 1040, 1040XL, 3060 Touchscreen

SOFTWARE

Feed Supervisor®



DIGI-STAR®

INDICATORS

Models: COMPACT EZ400, EZ2810, EZ3410, EZ3610

SOFTWARE

TRM Tracker®
Beef Tracker



DINAMICA GENERALE®

INDICATORS

Models: DG400, DG500, DG600, DG8000

SOFTWARE

DTM®
Daily TMR Tracker



CAB CONTROLS



REMOTE DISPLAYS



SMART DEVICES

Data Management

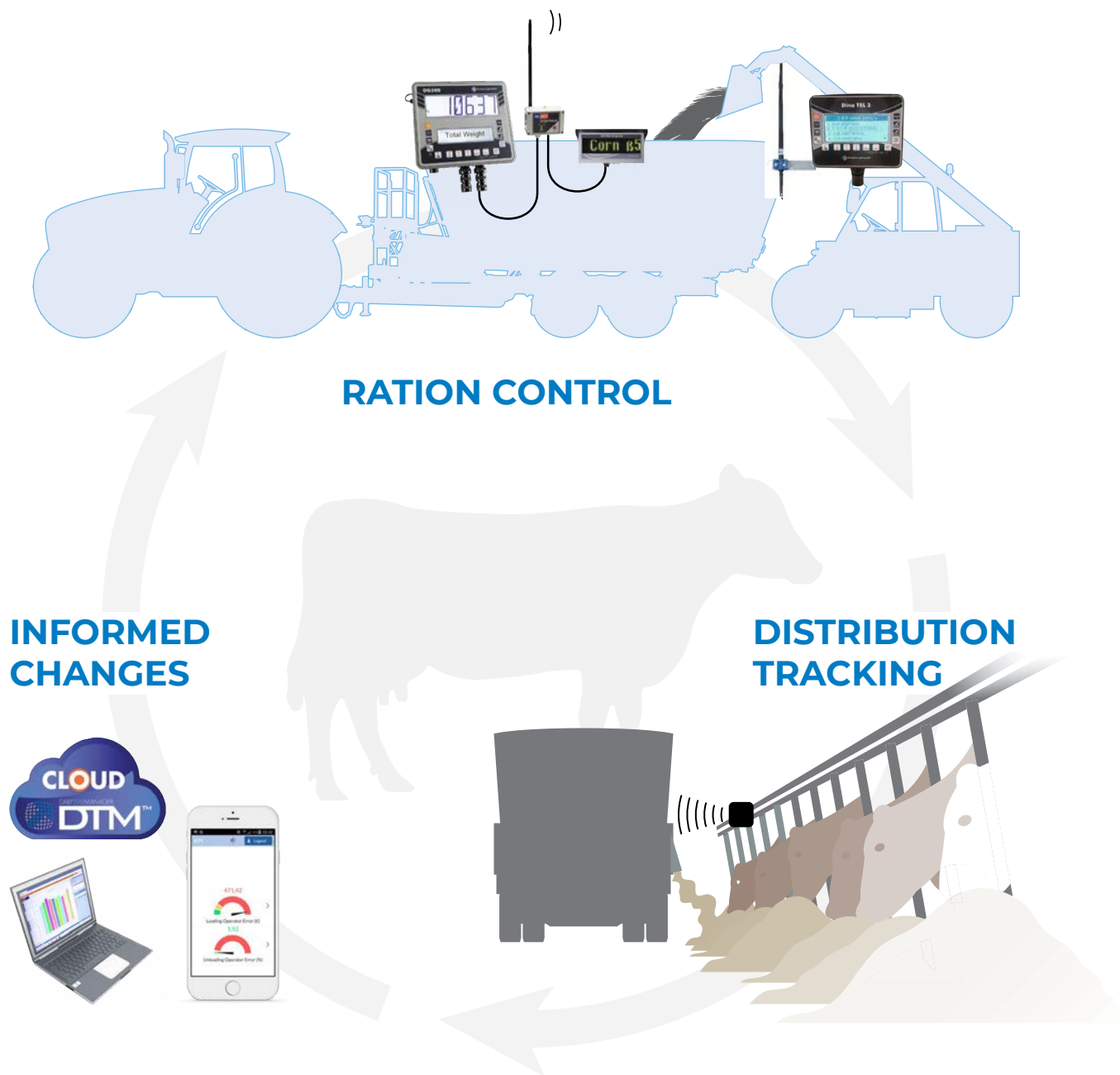

Feeding management for balanced daily nutrition

- Daily ration program and distribution management
- Increased production and animal health through consistent rations
- Manage ingredients, pen and ration changes
- Track each and every feeding process and monitor performance achieved

Information Provided by:
dinamica generale[®]
Electronic Solutions & Sensors

TRAILER MOUNTED MIXERS



Customization is Key

Every farm or feedlot is unique like their feeding program or individual rations.

Patz Vertical Mixers with Balanced Flow™ Technology are designed to deliver the Patz signature “rolling boil” mix.

Your authorized Patz Dealer will help design a mixer for your operation’s needs. Choose from 4-6 discharge door positions (with or without) conveyor options, choice of transmission, and several optional features.

Standard Features

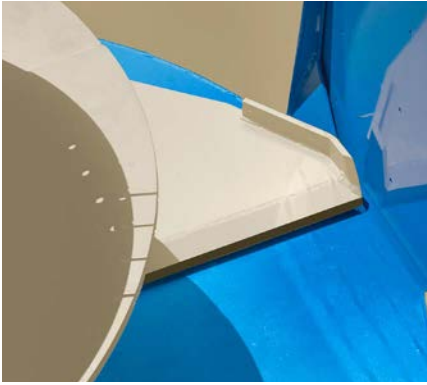

PRECISION FITTED SCREWS

Patz screws are designed for sidewall mixing action, material lift, and cleanout. The welded plow wing maintains Balanced Flow™ by keeping walls clean on every rotation.



PATENTED BAFFLES

Baffles gently direct all ingredients around both screws from mixer end to end for a thorough TMR in twin and triple screw mixers. Constructed of ¼" (⅜" for XH) steel for durability & long life.

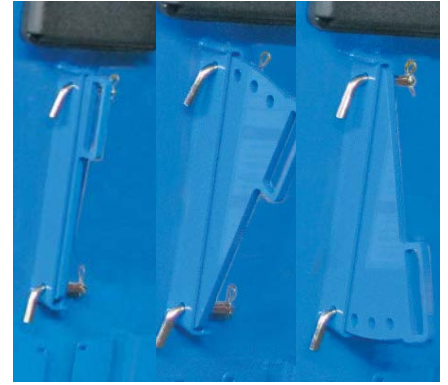

RESTRICTORS

Reversible restrictors are located on front left and right rear of tub. Adjust in or out to control the flow of forages inside. Longer forages can be processed faster by setting restrictors further in.



PLANETARY GEARBOX

Strong planetary gearboxes are backed by a 5-year, prorated planetary gearbox warranty. Grease zerks are easily accessible.



OVERLAPPED SIDEWALLS

Flared tub ends and vertical sidewalls are overlapped and double-joined by an exterior anchor weld and interior seam weld.



TOP RING

The ½" (12.7mm) top ring is critical to mixer strength and shapes the tub while allowing sidewalls to flex. It absorbs round bale shock and deflects the loader bucket.



SOLID CHASSIS

Underslung "A" frame design provides 16-18" of support (depending on mixer size) where forces are greatest. The solid frame allows for a shorter turning radius. Available on select mixers.



VIEWING PLATFORM

Safely view ration mixing from front viewing platform, providing left and right access. Available on select mixers.



LED TAIL LIGHTS

LED Tail lights with 7-pin connector provide higher visibility on public roads. Lights are recessed into back channel for added protection from accidental damage.

Optional Features

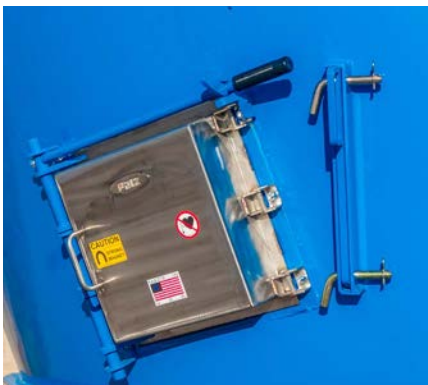

PATENTED TUB MAGNET

This Patz Exclusive patented magnet is strong enough to pull tramp metal from the ration while mixing. Quick release opening system allows for safe and easy cleaning and servicing.



DISCHARGE MAGNET

Help protect your livestock by removing trace metal from rations before it reaches your herd.

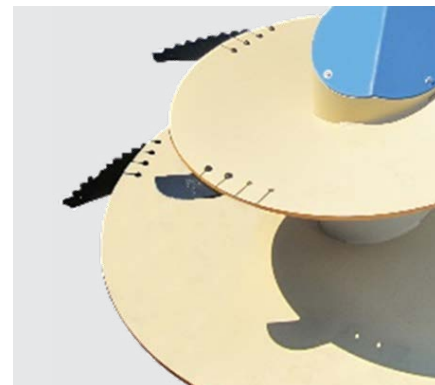

MIXING KNIVES

Add knives to cut long stemmed material. Choice of tungsten carbide or Patented Raptor™ knives in a variety of sizes.



RUBBER SIDE EXTENSION

Single screw mixers have an all rubber extension for an additional 9 1/4" height. Double and triple screw mixers have an extension combined of steel and rubber for extra durability.



CHAIN HAY RETAINER

Bolted to the top of the mixer tub, a hay retainer helps guide dry hay inside the tub during mixing.



TUB LINER

Choice of 3/16" thick steel or 11 gauge stainless steel for additional wear protection of mixer tub.



SELF-STEERING

Self-steering axles feature hydraulic brakes and six, super single truck tires. Limited to select models.



SCALES/INDICATORS

Increase your profits by accurately weighing feed ingredients with Avery Weigh-Tronix®, Digi-Star®, or dinamica generale® scales.



CAMERA PACKAGE

The 7" LCD monitor is great for backing up and discharging feed. Camera is weatherproof and shock-resistant.

Trailer TMR Mixers

Drive Options



2 SPEED MANUAL

Lowers the torque on the tractor when mixing heavy loads. PTO must be shut off in order to shift into desired gear.

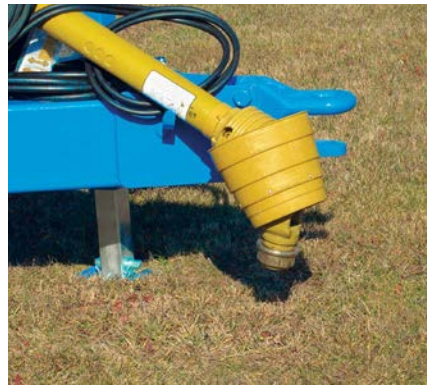

CV ARTICULATED PTO

Constant Velocity (CV) joint is located on a PTO drive shaft. Gearboxes are protected by an automatic cut-out clutch from tractor and 5-year prorated warranty. Available on select units.

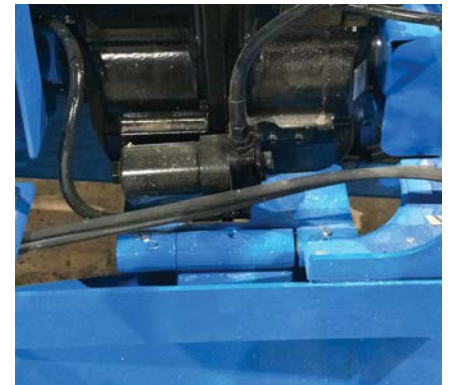

AUTOSHIFT

Programmable 2-speed transmission utilizes real-time driveline torque input to optimize shifting. Three flexible modes: Fully, Semi-, and Custom Automatic. Bluetooth remote monitoring available.





AUTO CLUTCH PROTECTION

Located on the rear drive line, a shear bolt provides added protection for the rear planetary gearbox.

Discharge Options



FRONT DISCHARGE CONVEYOR

Can be trailer mounted (feed not weighed on conveyor) or tub mounted (feed weighed on conveyor).



FLAT W/INCLINE EXTENSION

Flat with incline extension and fixed incline conveyors. Extensions with right-hand or left-hand discharge also available.

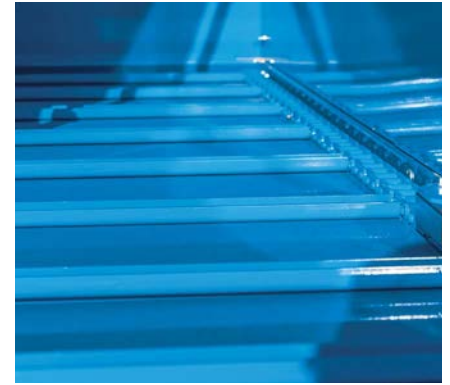

FLAT CONVEYOR

Choice of fixed or sliding flat conveyors with right-hand, left-hand, or reversible discharge.



SIDE DISCHARGE(S)

Side doors can be equipped with a chain conveyor discharge with collapsible steel sides. Available in hydraulic or manual operation.



SIDE CONVEYORS

Side discharge conveyors are 36" wide with choice of 36" or 54" lengths.



REAR COMMODITY

Pre-mix commodities once & empty into a storage bin. Back mixer into narrow spaces for emptying, and streamline your mixing process.

BUILT TOUGH, WORKS HARD

All Patz Vortex® and Tru Taper™ screws include AR 400 Steel on high wear areas including the nose, plow wing, and kicker.

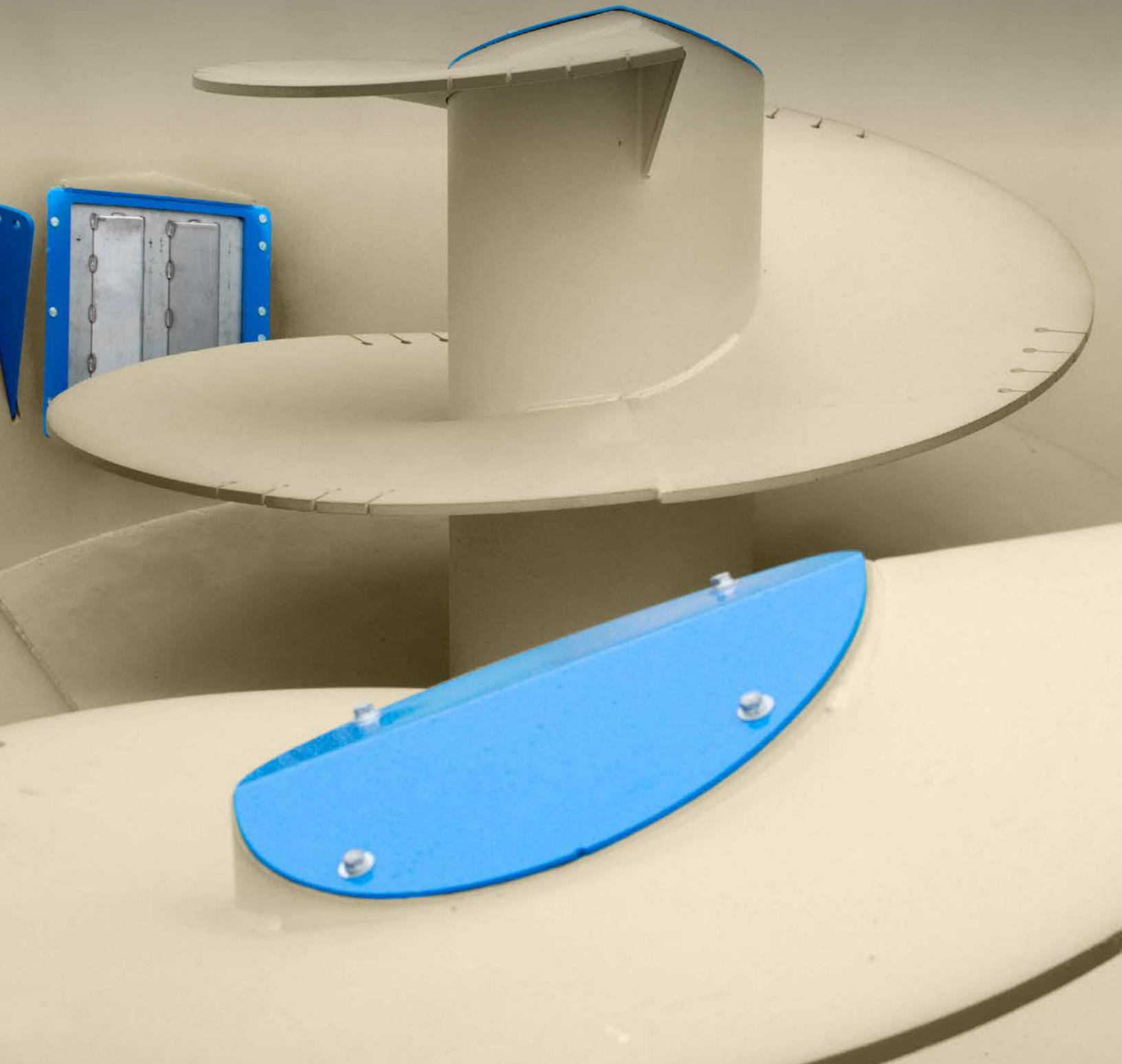



BALANCED FLOW™

Technology





Detailed Vertical Mixer Specifications (Trailer)

	U/M	800 Series II		1000 Series	420 / 420XH
		270 Low Profile	350	420	
CAPACITY					
Mixing	ft ³ (m ³)	270(7.6)	350(9.9)	420 (11.8)	420 (11.8)
w/Optional Extension	ft ³ (m ³)	315(8.9)	400(11.3)	490 (13.9)	490 (13.9)
UNIT					
Empty Wt.	lb (kg)	5,370(2435.8)	5,750(2608.1)	8,133 (3689)	9,500 (4,309)
XH Empty Wt.	lb (kg)	N/A		N/A	11,186 lbs (5073.9 kg)
Max. Load @ 25#/cu.ft.	lb (kg)	6,750(3062)	8,750(3969)	10,500 (4763)	10,500 (4763)
Max. Gross Wt.	lb (kg)	12,120(5510)	14,500(6590)	18,633 (8452)	20,000 (9072)
XH Max. Gross Wt.	lb (kg)	N/A		N/A	21,686 (9836)
No. of Screws (See Options below)		1			1
Overall Length	in (m)	175(4.4)	182(4.6)	201 (5.1)	220 (5.6)
Overall Height	in (m)	95(2.4)	100(2.5)	97 (2.5)	97 ½ (2.5)
Overall Height (W/ Powershift)	in (m)				N/A
Overall Width	in (m)	104(2.6)		118 ½ (3)	
Screw Flighting Thickness	in (mm)	½ (13)		⅝ (16)	
Floor Thickness	in (mm)	½ (13)		½ (13)	
Sidewall Thickness	in (mm)	¼ (6)		¼ (6)	
Minimum PTO Horsepower*		55 HP	65 HP	85 HP	85 HP
Viewing Platform		N/A			Access From Both Sides
Hour Meter					Standard
Drive Package		Direct Drive			
Scale System		3-Point		3-Point	
Trailer Type		Single		Dual	
No. of Tires		2		4	
Tire Size		320 70R 15 Tubeless Implement Tire		245 70R 19.5 Tubeless Imp	
Operating Speed		540		540 or 1000	
DOOR OPENINGS					
Front/Rear Commodity					
Height	in (mm)	N/A	30 (762) (Rear only)	26 (660) (Rear only)	
Width	in (mm)	N/A	34 (864) (Rear only)	42 (1,067) (Rear only)	
Side (4 Locations)					
Height	in (mm)			39 (991)	
Width	in (mm)			34 (864)	
Discharge				Various discharge packages available See Dealer for details	
Ground Clearance				Varies with discharge s	
OPTIONS					
Vertical Mixer Screw		Tru Taper™ Dual Kicker - Cone Top		Vortex® Choose One Type of Screw Single or Dual Kicker - Multi-An	
Maximum No. of Knives+		5		7	5
Steel/Rubber Side Extensions				Optional	
Hay Retainer Option(s)				Chain or Pipe	
Discharge Chute w/ or w/out Magnet				Optional	
Discharge Conveyor(s)				Various Options Avail	
Tub Mounted Magnet**				Optional	
Wide Selection of Indicators				Digi-Star®, dinamica generale®,	
Camera Package				Optional	
Ladder (Rear Location)				Optional	
Planetary Cooling System				N/A	
Hydraulic Control Center				N/A	

*Minimum PTO horsepower requirement is for continuous run. Starting the mixer under load will require higher PTO horsepower. **Patented +Quantity varies with



1200 Series 500 / 500XH		615 / 615XH	1600 Series 620	1600 Series II 620
500 (14.2)		615 (17.4)	620 (17.6)	620 (17.6)
575 (16.3)		690 (19.5)	720 (20.3)	720 (20.3)
9,980 (4527)		10,475 (4751)	11,900 (5398)	13,700 (6214)
11,743 lbs (5326.5 kg)		12,373 lbs (5612.3 kg)	N/A	
12,500 (5670)		15,375 (6,974)	15,500 (7031)	15,500 (7031)
22,480 (10196)		25,850 (11725)	27,400 (12429)	29,200 (826)
24,243 (10996)		27,748 (12856)	N/A	
			2	2
223 3/4 (5.7)		228 (5.8)	270 (6.86)	288 (7.31)
106 1/8 (2.7)		119 1/8 (3)	102 (2.6)	103.5 (2.62)
109 (2.8)			101 (2.57)	101 (2.57)
5/8 (16), 3/4 (19) XH			5/8 (16)	
3/4 (19)			5/8 (16)	
1/4 (6), 3/8 (9.5) XH			1/4 (6)	
90 HP		110 HP	80 / 120 HP	80 / 120 HP
			N/A	Access From Both Sides
Direct Drive or 2-Speed				
4-Point			3-point	3-point
Split Dual			Single	Dual
4			2	4
Implementation Tire			H40 x 14.5 Recapped Aircraft	285 70R 19.5 Tubeless Implement Tires
			1000	
26 (660)			30 (762)	30 (762)
42 (1,067)			39 (991)	39 (991)
Options available.				
Options available.				
Options selected.				
Options for your Mixing Needs		Tru Taper™ Choose One Type of Screw for your Mixing Needs		
Single or Cone Top		Dual Kicker - Multi-Angle or Cone Top		
7		11	7 Per Screw/14 Total	7 Per Screw/14 Total
Options available.				
Options & Weigh-Tronix®				
			N/A	
Optional				
Optional				
material in the ration and processing time.				



Detailed Vertical Mixer Specifications (Trailer)

		1800 Series						
	U/M	265	510	750	650 / 650XH	750 / 750XH	8	
CAPACITY								
Mixing	ft ³ (m ³)	265 (7.5)	510 (14.4)	750 (21.2)	650 (18.4)	750 (21.2)		
w/Optional Extension	ft ³ (m ³)	Up to 330 (9.3)	Up to 620 (17.5)	Up to 910 (25.8)	755 (21.4)	859 (24.3)		
UNIT								
Empty Wt.	lb (kg)	7,400 (3363)	13,100 (5953)	21,000 (9525)	16,500 (7484)	17,500 (7938)	11	
XH Empty Wt.	lb (kg)		N/A		18,000 (8165)	19,400 (8800)	21	
Max. Load @ 25#/cu.ft.	lb (kg)	6,625 (3005)	12,750 (5783)	18,750 (8504)	16,250 (7371)	18,750 (8505)	2	
Max. Gross Wt.	lb (kg)	14,025 (6368)	25,850 (11736)	39,750 (18029)	32,750 (14855)	36,250 (16443)	38	
XH Max. Gross Wt.	lb (kg)		N/A		34,250 (15535.5)	38,150 (17304.5)	40	
No. of Screws (See Options below)		1	2	3				
Overall Length	in (m)	197 ½ (5)	284 (7.2)	370 ½ (9.4)	302 (7.6)	304.5 (7.7)		
Overall Height	in (m)		98 ¾ (2.51)	102 (2.6)	102 (2.59)	111 (2.82)		
Overall Height (W/ Powershift)	in (m)		N/A		N/A	N/A		
Overall Width	in (m)	87 (2.2)	Each side door adds 9 ¼ (235) to width of mixer.		97 (2.5)	97 (2.5)		
Screw Flighting Thickness	in (mm)		5/8 (16)					
Floor Thickness	in (mm)		5/8 (16)					
Sidewall Thickness	in (mm)		1/4 (6)					
Minimum PTO Horsepower*		55 HP	65 HP	145 HP (LO) speed	130 HP	150 HP		
Viewing Platform					Access From Both Sides			
Hour Meter								
Drive Package		Direct Drive	Direct Drive or 2-Speed	2-Speed	Direct Drive or 2-Speed			
Scale System			4-point					
Trailer Type		Single	Split Dual	Split Dual Walking Beam	Split Dual			
No. of Tires		2	4	8	4			
Tire Size		245 70R 19.5 Tubeless Implement Tires			285 70R 19.5 Tubeless Implement Tires			
Operating Speed		540 or 1000		1000 RPM				
DOOR OPENINGS								
Front/Rear Commodity								
Height	in (mm)		26 (660)		26 (660)	30 (762)		
Width	in (mm)		42 (1,067)					
Side (4 Locations)								
Height	in (mm)							
Width	in (mm)							
Discharge								
Ground Clearance								
OPTIONS								
Vertical Mixer Screw		Tru Taper™ Choose One Type of Screw for your Mixing Needs						
		Dual Kicker - Multi-Angle or Cone Top						
Maximum No. of Knives+		7	7 per screw/14 total	7 per screw/21 total	7 per screw/14 total	9 per screw/18 total	5	
Steel/Rubber Side Extensions								
Hay Retainer Option(s)			N/A			Chain or P		
Discharge Chute w/ or w/out Magnet								
Discharge Conveyor(s)								
Tub Mounted Magnet**								
Wide Selection of Indicators							Dis	
Camera Package								
Ladder (Rear Location)								
Planetary Cooling System								
Hydraulic Control Center								

*Minimum PTO horsepower requirement is for continuous run. Starting the mixer under load will require higher PTO horsepower. **Patented +Quantity varies with



2400 Series II				3600 Series II	
10 / 810XH	950 / 950XH	1100 / 1100XH	1100 / 1100XH Walking Beam	1400 Non-Steering Axle	1400 Self-Steering Axle
810 (22.9)	950 (26.9)	1,100 (31.1)	1,100 (31.1)	1,400 (39.6)	1,400 (39.6)
950 (26.9)	1,100 (31.1)	1,270 (36)	1,270 (36)	1,580 (44.7)	1,580 (44.7)
8,670 (8468.6)	19,790 (8976.6)	20,980 (9516.4)	24,200 (10976)	34,820 (15794)	35,020 (15885)
0,550 (9321.3)	22,322 (10125.0)	23,746 (10771.0)	26,966 (12231)	N/A	N/A
20,250 (9185)	23,750 (10773)	27,500 (12,474)	27,500 (12,474)	35,000 (15876)	35,000 (15876)
9,920 (17653.8)	43,540 (19749.4)	48,480 (21990.2)	51,700 (23451)	69,820 (17826)	70,020 (31761)
1,800 (18506.6)	46,072 (20897.9)	51,246 (23326.4)	54,466 (24705)	N/A	
2				3	
325 (8.3)	329 (8.4)	358 (9.1)	358 (9.1)	420 ¼ (10.7)	
99 (2.5)	108 ¼ (2.7)	131 (3.3)	120 (3)	128 (3.3)	132 (3.4)
102 (2.56)	110 ¼ (2.80)	133 (3.4)	122 (3.1)	N/A	
109 (2.8)	109 (2.8)	109 (2.8)	109 (2.8)	107 ¾ (2.7)	
5/8 (16), ¾ (19) XH				¾ (19)	
¾ (19)				¾ (19)	
¼ (6), ⅜ (9.5) XH				5/16 (8)	
125 HP	145 HP	170 HP		200 HP (LO) speed	
Standard				Access From Left Sides	
2-Speed Gearbox, Powershift, or Autoshift.					
4-Point					
Split Dual Walking tandem			or Self-Steering Axle		Tri-Axle
8			4 Super Singles		6 (Super Singles)
245 70R 19.5 Tubeless Implement Tires			385 / 65 R22.5		385 / 65 R22.5
1000 RPM					
26 (660)	30 (762)	30 (762)		30 (762)	
42 (1,067)					
39 (991)					
34 (864)					
Various discharge packages available. See Dealer for details.					
Varies with discharge selected.					
Vortex ® Choose One Type of Screw for your Mixing Needs Single or Dual Kicker - Multi-Angle or Cone Top				Vortex ® Choose One Type of Screw for your Mixing Needs Single or Dual Kicker - Multi-Angle or Cone Top	
per screw/10 total	7 per screw/14 total	11 per screw/22 total	11 per screw/22 total	7 per screw/21 total	7 per screw/21 total
Optional					
Pipe		Chain		Chain or Pipe	
Optional					
Various Options Available					
Optional					
Sj-Star®, dinamica generale®, & Weigh-Tronix®					
Optional					
Optional					
Optional					
Optional					

material in the ration and processing time.



STATIONARY MIXERS



Standard Features

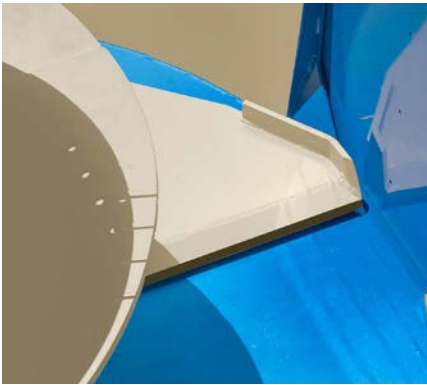

PRECISION FITTED SCREWS

Patz screws are designed for sidewall mixing action, material lift, and cleanout. The welded plow wing maintains Balanced Flow™ by keeping walls clean on every rotation.



PATENTED BAFFLES

Baffles gently direct all ingredients around both screws from mixer end to end for a thorough TMR in twin and triple screw mixers. Constructed of ¼" (⅜" for XH) steel for durability & long life.

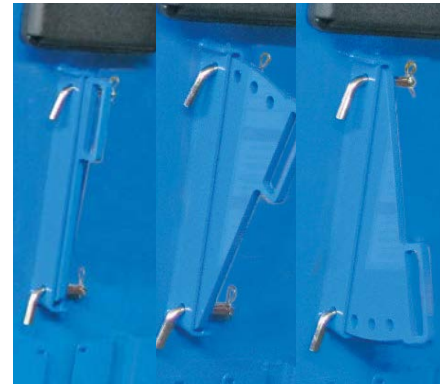

RESTRICTORS

Reversible restrictors are located on front left and right rear of tub. Adjust in or out to control the flow of forages inside. Longer forages can be processed faster by setting restrictors further in.



PLANETARY GEARBOX

Strong planetary gearboxes are backed by a 5-year, prorated planetary gearbox warranty. Grease zerks are easily accessible.



OVERLAPPED SIDEWALLS

Flared tub ends and vertical sidewalls are overlapped and double-joined by an exterior anchor weld and interior seam weld.



SAFETY GRID

Designed to prevent accidental entry into the mixing chamber from above. Top guard meets ASABE® safety standards.

Stationary TMR Mixers

Optional Features

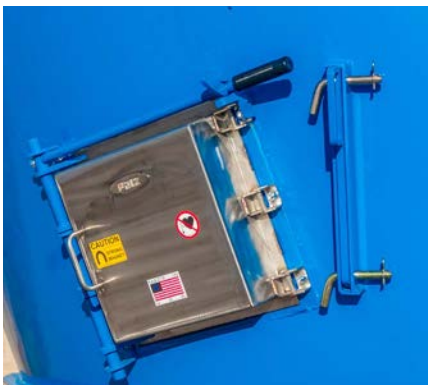

PATENTED TUB MAGNET

This Patz Exclusive patented magnet is strong enough to pull tramp metal from the ration while mixing. Quick release opening system allows for safe and easy cleaning and servicing.



DISCHARGE MAGNET

Help protect your livestock by removing trace metal from rations.

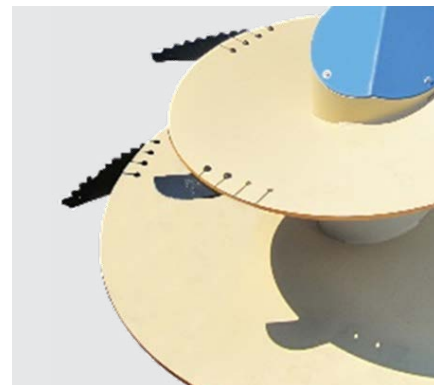

MIXING KNIVES

Add knives to cut long stemmed material. Choice of tungsten carbide or Patented Raptor™ knives in a variety of sizes.

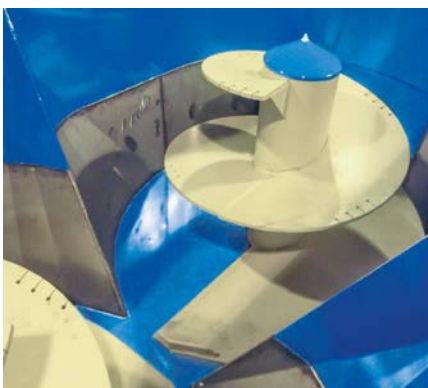

TUB LINER

Choice of $\frac{3}{16}$ " thick steel or 11 gauge stainless steel for additional wear protection of mixer tub.



Drive Options

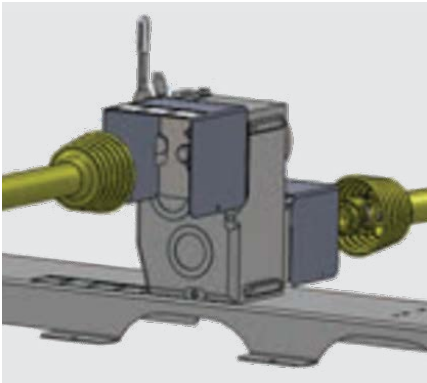

2-SPEED

For both PTO or electric motor drives, the manual stop-and-shift High-Low transmission reduces drive power requirements.

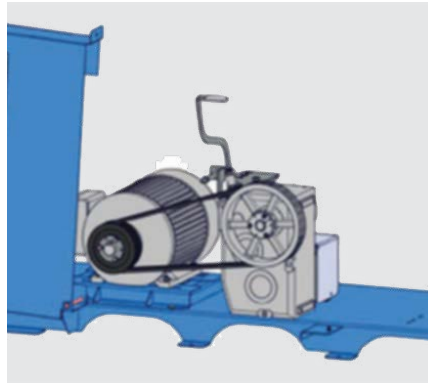

BELT & PULLEY

Designed for 1 motor or 2, the belt and pulley option offers drive reduction and system safety. Available with double reduction and 2-speed transmission.

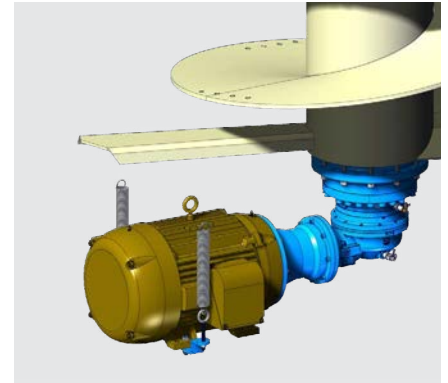

DIRECT ELECTRIC DRIVE

Direct Electric Drive (DED) is self-contained under mixer for installation versatility. More efficiency—less power transmission loss.

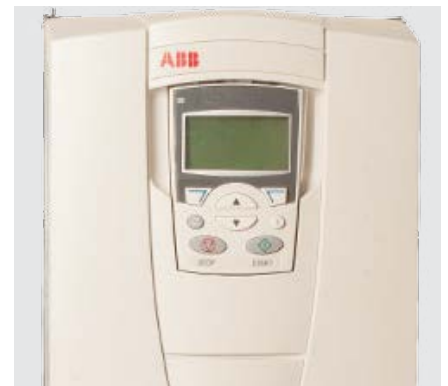

VARIABLE FREQUENCY DRIVE

VFD control package is TMR control including: built-in soft start, 3 forward speeds, 30-second BOOST for screw clean-off, and reverse.

Stationary TMR Mixers

Discharge Options

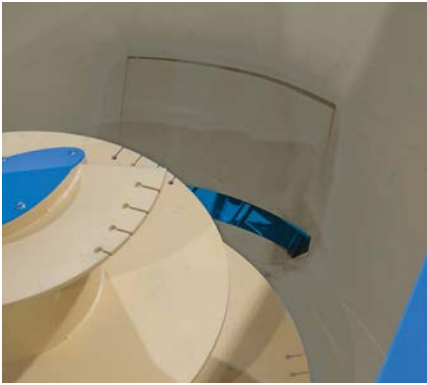

REAR COMMODITY

Pre-mix commodities once & empty into a storage bin. Capable of being installed in narrow spaces.



SIDE DISCHARGE(S)

Side doors can be equipped with a chain conveyor discharge with collapsible steel sides. Available in hydraulic or manual operation.



HYDRAULIC OPERATIONS

Discharge doors for vertical mixers are able to be opened and closed manually or hydraulically. Conveyor discharge systems also operate with hydraulics.



Feeding Options



SURFACE & RING DRIVE SILO UNLOADERS



12-36" BELT CONVEYORS



CHAIN & FLITE CONVEYORS

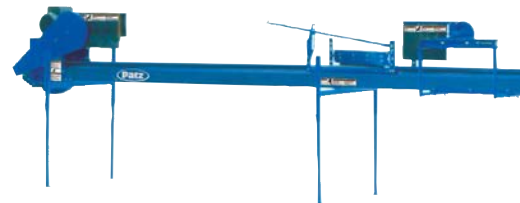

12-24" BELT FEEDERS

Detailed Vertical Mixer Specifications (Stationary)

	U/M	400 Series II		600 Series	800 Series II		420
		140	200	185	270 Low Profile	350	
CAPACITY							
Mixing	ft ³ (m ³)	140 (3.9)	200 (5.7)	185 (5.2)	270 (7.6)	350 (9.9)	420 (11.9)
w/Optional Extension	ft ³ (m ³)	180 (5.0)	240 (6.8)	235 (6.6)	335 (9.5)	425 (12)	490 (13.8)
UNIT							
Empty Wt.	lb (kg)	4,184 (1898)	4,575 (2075)	5,517 (2503)	5,995 (2719)	6,446 (2924)	7,400 (3358)
Max. Load @ 25#/cu.ft.	lb (kg)	3,500 (1588)	5,000 (2268)	4,625 (2102)	6,750 (3062)	8,750 (3969)	10,500 (4763)
Max. Gross Wt.	lb (kg)	7,684 (3486)	9,575 (4343)	10,142 (4600)	12,745 (5781)	15,196 (6893)	17,900 (8068)
No. of Screws (See Options below)		1					
Overall Length	in (m)	118 ½ (3.0)	118 ½ (3.0)	120 (3.0)	132 ½ (3.4)	146 ⅝ (3.7)	152 ¾ (3.9)
Overall Height	in (m)	86 ⅞ (2.2)	100 ⅜ (2.5)	86 ⅞ (2.2)	91 ½ (2.3)	97 ½ (2.5)	93 (2.4)
Overall Width	in (m)	79 ½ (2)	79 ½ (2)	84 ⅞ (2.1)	103 ⅞ (2.6)	103 (2.6)	
Overall Height w/Side Ext.	in (m)	95 ⅞ (2.4)	109 ⅜ (2.8)	98 (2.5)	103 ½ (2.6)	109 ½ (2.8)	103 ⅞ (2.7)
Screw Flighting Thickness	in (mm)	½ (13)					
Floor Thickness	in (mm)	½ (13)					
Sidewall Thickness	in (mm)	¼ (6)					
Hour Meter							
Drive Package		Choice of PTO or Electric (Direct, VFD, or 2-Speed)					
Scale System		3-Point					
Operating Speed		540 or 1000					
DOOR OPENINGS							
Front/Rear Commodity							
Height	in (mm)	N/A	N/A	N/A	26 (660)	30 (762)	
Width	in (mm)	N/A	N/A	N/A			
Side							
Height	in (mm)	31 (787)	31 (787)	31 (787)	39 (991)		
Width	in (mm)	24 (610)	24 (610)	24 (610)	34 (864)		
Discharge							
OPTIONS							
Vertical Mixer Screw		Tru Taper™ Dual Kicker - Cone Top - 1 per unit					
Maximum No. of Knives+		4	5	4 (34"H), 5 (44"H)	5	7	
Side Extensions							
Hay Retainer Option(s)		N/A					
Discharge Chute w/ or w/out Magnet							
Discharge Conveyor(s)							
Tub Mounted Magnet**							
Indicator Extension Arm							
Wide Selection of Indicators							
Motor Control VFD							
Ladder							

*Minimum PTO horsepower requirement is for continuous run. Starting the mixer under load will require higher PTO horsepower. **Patented +Quantity varies with material



1200 Series			1800 Series			2400 Series II		
500	615	265	510	750	810	950	1100	
500 (14.2)	615 (17.4)	265 (7.5)	510 (14.4)	750 (21.2)	810 (22.9)	950 (26.9)	1,100 (31.1)	
575 (16.3)	690 (19.5)	Up to 330 (9.3)	Up to 620 (17.5)	Up to 910 (25.8)	950 (26.9)	1,100 (31.1)	1,270 (36)	
7,750 (3515)	8,350 (3787)	6,415 (2937)	11,970 (5430)	17,400 (7893)	15,975 (7246)	16,925 (7677)	17,975 (8153)	
12,500 (5670)	15,375 (6974)	6,625 (3005)	12,750 (5783)	18,750 (8504)	22,500 (10206)	25,000 (11340)	27,500 (12474)	
20,250 (9185)	23,725 (10761)	13,100 (59942)	24,720 (11213)	36,150 (16397)	38,475 (17452)	41,925 (19016)	45475 (20627)	
			2	3	2			
159 ½ (4.1)	168 ½ (4.3)	132 ¼ (3.3)	218 ¾ (5.5)	305 ¾ (7.7)	261 ¼ (6.6)	268 ¼ (6.8)	277 ¾ (7.1)	
102 ½ (2.6)	114 ¾ (2.9)	95 ¾ (2.4)	97 ¼ (2.5)	97 ¼ (2.5)	97 ¾ (2.5)	106 ½ (2.7)	120 (3)	
109 (2.8) + 9 ½ (0.24) per side with discharge(s)								
111 ½ (2.8)	123 ¾ (3.1)	107 ¾ (2.7)	109 ¼ (2.8)	109 ¼ (2.8)	108 ¼ (2.7)	117 (3)	130 ½ (3.3)	
5/8 (16)								
5/8 (16)					3/4 (19)			
1/4 (6)								
Standard								
			Direct Electric Drive			PTO or Direct Electric		
4-Point								
1000 RPM								
26 (660)			26 (660)			26 (660)		30 (762)
34 (864)						42 (1,067)		
39 (991)								
34 (864)								
Various discharge packages available. See Dealer for details.								
Vortex® Choose One Type of Screw for your Mixing Needs Single or Dual Kicker - Multi-Angle or Cone Top			Tru Taper™ Choose One Type of Screw for your Mixing Needs Single or Dual Kicker - Multi-Angle or Cone Top - 2 per unit			Vortex® Choose One Type of Screw for your Mixing Needs Single or Dual Kicker - Multi-Angle or Cone Top		
9		9	5 per screw (34"H)+		7 per screw (44"H)+	5 per screw/10 total	7 per screw/14 total	11 per screw/22 total
Steel/Rubber								
Chain			N/A			Chain		
Optional								
Various Options Available								
Optional								
Optional								
Sgi-Star®, dinamica generale®, & Weigh-Tronix®								
Optional								
Optional								

Material in the ration and processing time.



TRUCK MOUNTED MIXERS



Truck Mounted TMR Mixers

Standard Features

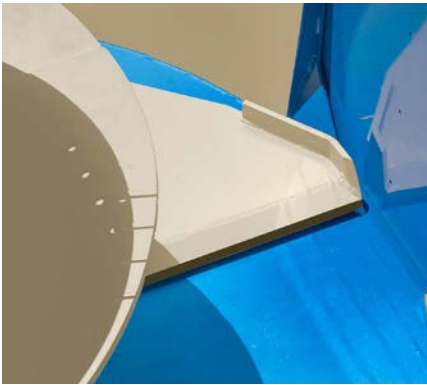

PRECISION FITTED SCREWS

Patz screws are designed for sidewall mixing action, material lift, and cleanout. The welded plow wing maintains Balanced Flow™ by keeping walls clean on every rotation.



PATENTED BAFFLES

Baffles gently direct all ingredients around both screws from mixer end to end for a thorough TMR in twin and triple screw mixers. Constructed of ¼" (⅜" for XH) steel for durability & long life.



RESTRICTORS

Reversible restrictors are located on front left and right rear of tub. Adjust in or out to control the flow of forages inside. Longer forages can be processed faster by setting restrictors further in.



PLANETARY GEARBOX

Strong planetary gearboxes are backed by a 5-year, prorated planetary gearbox warranty. Grease zerks are easily accessible.



OVERLAPPED SIDEWALLS

Flared tub ends and vertical sidewalls are overlapped and double-joined by an exterior anchor weld and interior seam weld.



TOP RING

The ½" (12.7mm) top ring is critical to mixer strength and shapes the tub while allowing sidewalls to flex. It absorbs round bale shock and deflects the loader bucket.

Truck Mounted TMR Mixers

Optional Features

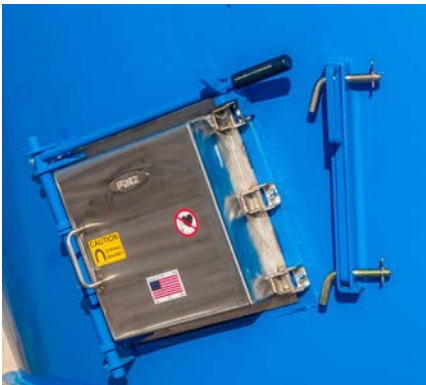

PATENTED TUB MAGNET

This Patz Exclusive patented magnet is strong enough to pull tramp metal from the ration while mixing. Quick release opening system allows for safe and easy cleaning and servicing.



DISCHARGE MAGNET

Help protect your livestock by removing trace metal from rations before it reaches your herd.

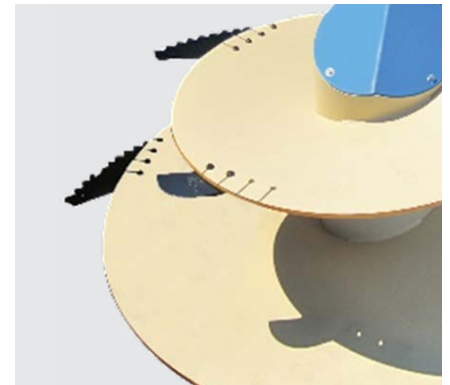

MIXING KNIVES

Add knives to cut long stemmed material. Choice of tungsten carbide or Patented Raptor™ knives in a variety of sizes.



CHAIN HAY RETAINER

Bolted to the top of the mixer tub, a hay retainer helps guide dry hay inside the tub during mixing.



RUBBER SIDE EXTENSION

Single screw mixers: all rubber extension. Double and triple screw mixers: rubber and steel extension combination for extra durability. Adds an additional 9 ¼" height.



TUB LINER

Choice of ¾" thick steel or 11 gauge stainless steel for additional wear protection of mixer tub.



VIEWING PLATFORM

View ration mixing from front viewing platform, providing left and right access.
Available on select models.



SCALES/INDICATORS

Increase your profits by accurately weighing feed ingredients with Avery Weigh-Tronix®, Digi-Star®, or dinamica generale® scales.



CAMERA PACKAGE

The 7" LCD monitor is great for backing up and discharging feed. Camera is weatherproof and shock-resistant.

Truck Mounted TMR Mixers

Discharge Options



FRONT DISCHARGE CONVEYOR

Can be trailer mounted (feed not weighed on conveyor) or tub mounted (feed weighed on conveyor).



FLAT W/INCLINE EXTENSION

Flat with incline and fixed incline conveyors with right-hand or left-hand discharge also available.

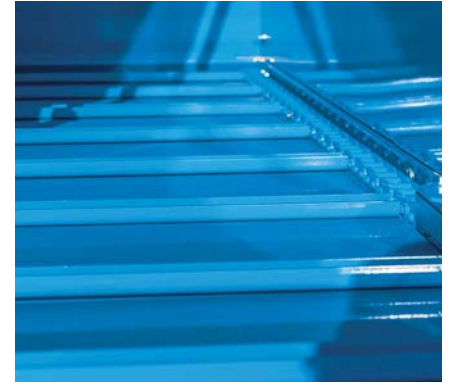

FLAT CONVEYOR

Choice of fixed or sliding flat conveyors with right-hand, left-hand, or reversible discharge.



SIDE DISCHARGE(S)

Side doors can be equipped with a chain conveyor discharge with collapsible steel sides. Available in hydraulic or manual operation.

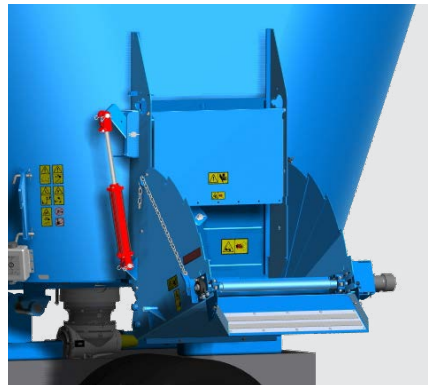

SIDE CONVEYORS

Side discharge conveyors are 36" wide with choice of 36" or 54" lengths.

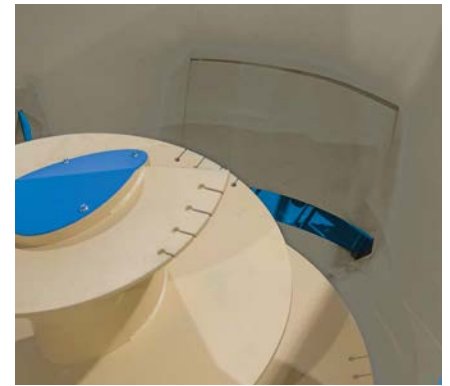

REAR COMMODITY

Pre-mix commodities once & empty into a storage bin, Back mixer into narrow spaces for emptying, and streamline mixing process.



Detailed Vertical Mixer Specifications (Truck Mount)

	U/M	1200 Series			1600 Series II
		420	500	615	620
CAPACITY					
Mixing	ft ³ (m ³)	420 (11.8)	500 (14.2)	615 (17.4)	620 (17.6)
w/Optional Extension	ft ³ (m ³)	490 (13.9)	575 (16.3)	690 (19.5)	720 (20.3)
UNIT					
Empty Wt.	lb (kg)	6,860 (3111)	7,280 (3302)	7,780 (3529)	10,500 (4773)
XH Empty Wt.	lb (kg)	N/A	N/A	N/A	N/A
Max. Load @ 25#/cu.ft.	lb (kg)	10,500 (4763)	12,500 (5670)	15,375 (6974)	15,500 (7031)
Max. Gross Wt.	lb (kg)	17,360 (7874)	19,780 (8972)	23,153 (10503)	26,000 (11804)
XH Max. Gross Wt.	lb (kg)	N/A	N/A	N/A	N/A
No. of Screws (See Options below)		1			
Overall Length	in (m)	152 ¾ (3.9)	159 ½ (4.1)	168 ½ (4.3)	227 (5.77)
Overall Height	in (m)	79.7 (2)	89.3 (2.3)	108 ½ (2.7)	99 ½ (2.5)
Overall Width	in (m)	109 (2.8)			101 (2.5)
Screw Flighting Thickness	in (mm)	⅝ (16)			⅝ (16)
Floor Thickness	in (mm)	¾ (19)			⅝ (16)
Sidewall Thickness	in (mm)	¼ (6)			¼ (6)
Hour Meter					Standard
Scale System					4-Point
Operating Speed					1000 RPM
DOOR OPENINGS					
Front/Rear Commodity Height	in (mm)	26 (660)	30 (762)		
Width	in (mm)	42 (1,067)		34 (864)	
Side (4 Locations) Height	in (mm)				39 (991)
Width	in (mm)				34 (864)
Discharge		Various discharge packages available. See Dealer for details.			
Ground Clearance		Varies with Truck			
OPTIONS					
Vortex® Vertical Mixer Screw Single or Dual Kicker		Vortex® Choose One Type of Screw for your Mixing Needs Single or Dual Kicker - Multi-Angle or Cone Top - 1 per unit			Tru Taper™ Choose One Type of Screw for your Mixing Needs Dual Kicker - Multi-Angle or Cone Top
Maximum No. of Knives+		7	9	9	7 Per Screw/14 Total
Side Extensions		Steel/Rubber			
Hay Retainer		Chain or Pipe			
Discharge Chute w/ or w/out Magnet		Optional			
Viewing Platform		Access From Left Side			
Discharge Conveyor(s)		Various Options Available			
Tub Mounted Magnet**		Optional			
Wide Selection of Indicators		Digi-Star®, dinamica generale®, & Weigh-Tronix®			
Camera Package		Optional			

*Minimum PTO horsepower requirement is for continuous run. Starting the mixer under load will require higher PTO horsepower. **Patented +Quantity varies with



2400 Series II		
810 / 810XH	950 / 950XH	1100 / 1100 XH
810 (22.9)	950 (26.9)	1,100 (31.1)
950 (26.9)	1,100 (31.1)	1,270 (36)
17,200 (7802)	18,470 (8378)	19,170 (8695)
19,000 (8618)	20,900 (9480)	22,000 (9979)
20,250 (9185)	23,750 (10773)	27,500 (12474)
37,450 (16987)	42,220 (19151)	49,170 (22303)
39,250 (17803)	44,650 (20252)	50,400 (22861)
2		
262 (6.7)	268 (6.8)	278 (7.1)
74 (1.9)	83.2 (2.1)	95.6 (2.4)
	109 (2.8)	
	5/8 (16), 3/4 (19) XH	
	3/4 (19)	
	1/4 (6), 3/8 (19) XH	

26 (660)	30 (762)	30 (762)
	42 (1,067)	

Vortex® Choose One Type of Screw for your Mixing Needs
Single or Dual Kicker - Multi-Angle or Cone Top - 1 per unit

5 per screw/10 total	7 per screw/14 total	11 per screw/22 total
----------------------	----------------------	-----------------------

material in the ration and processing time.





Patz Corporation
917 Business 141, POB 7 • Pound, Wisconsin 54161-0007
Ph: (920) 897-2251 • www.patzcorp.com

