

# **WIESER** CONCRETE

## Grain Storage Walls



**"It's the  
ENGINEERING that  
makes the  
difference."**

**Engineered  
Precast  
Self-supporting  
Concrete walls**



**800-325-8456**

[www.wieserconcrete.com](http://www.wieserconcrete.com)

**Proven performance from the industry leader!**

2 X 4 TREATED NAILER OPTIONAL  
 INSERTS FOR FASTENING NAILER  
 TO ATTACH COVER

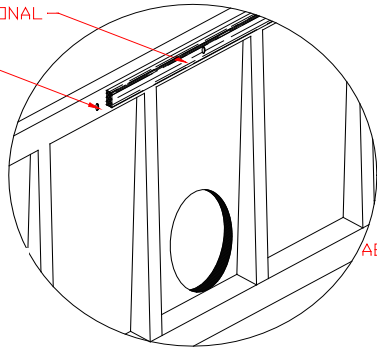

AERATION OPENINGS  
 VARIOUS SIZES

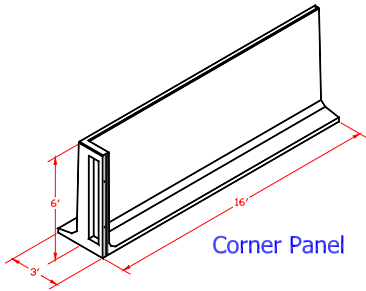

Corner Panel

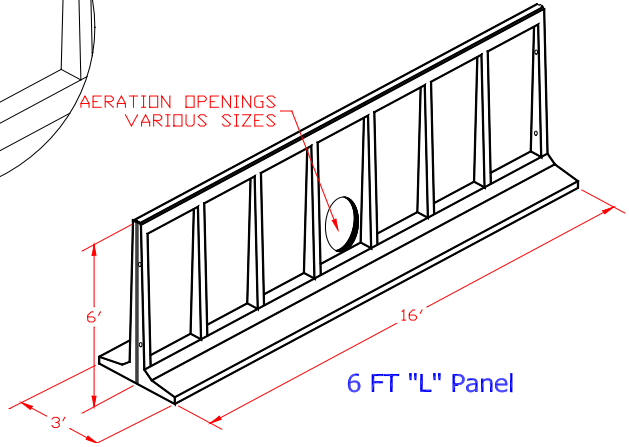

6 FT "L" Panel

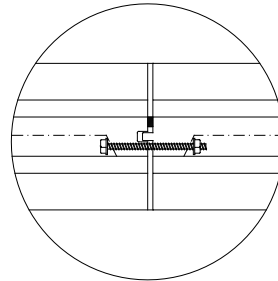
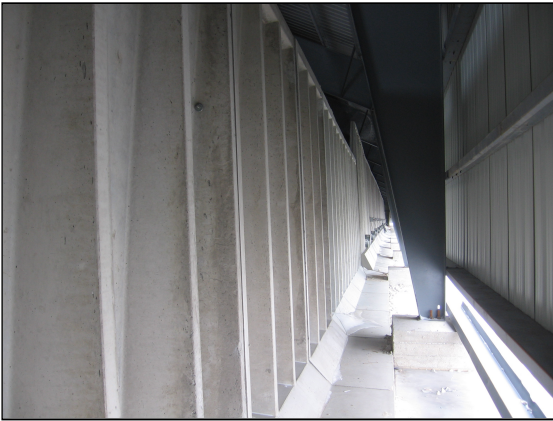

JOINT AND SEALANT  
 DETAIL

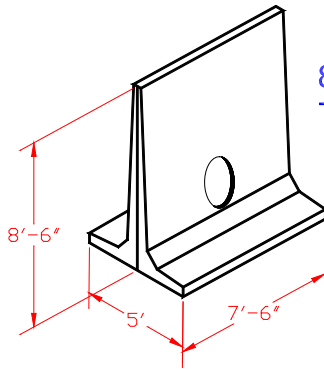

8'-6"  
 T Panel

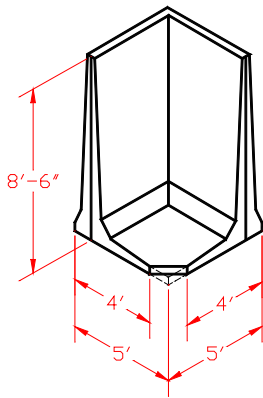

8'-6"  
 Corner Panel

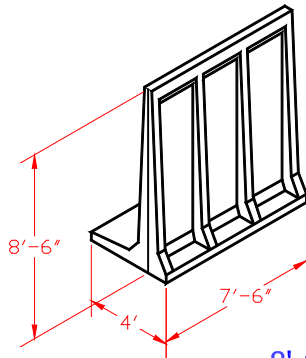

8'-6"  
 L-Panel

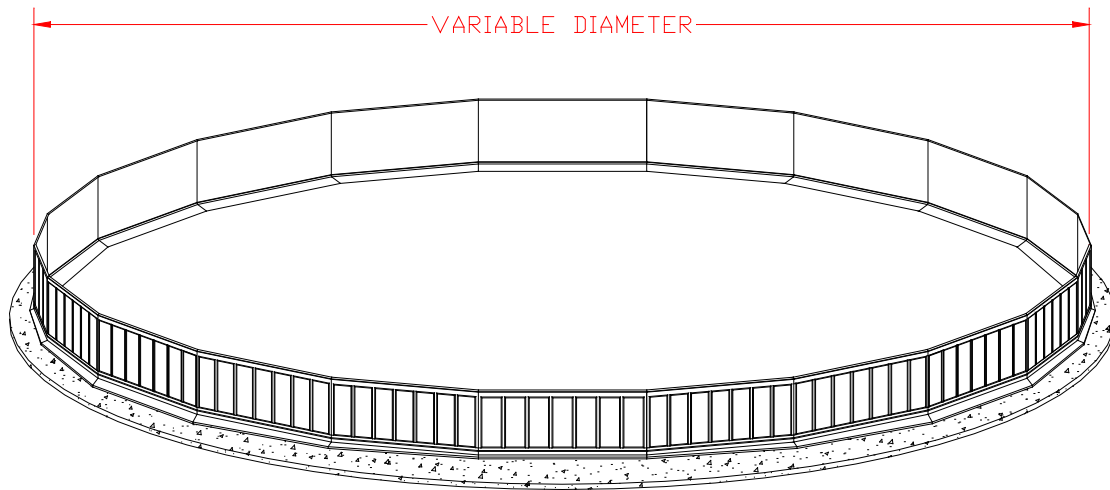

**Many sizes, shapes and configurations.  
Available heights 6', 8'-6", 10', 12', 16'.  
Call us for your customized design.**

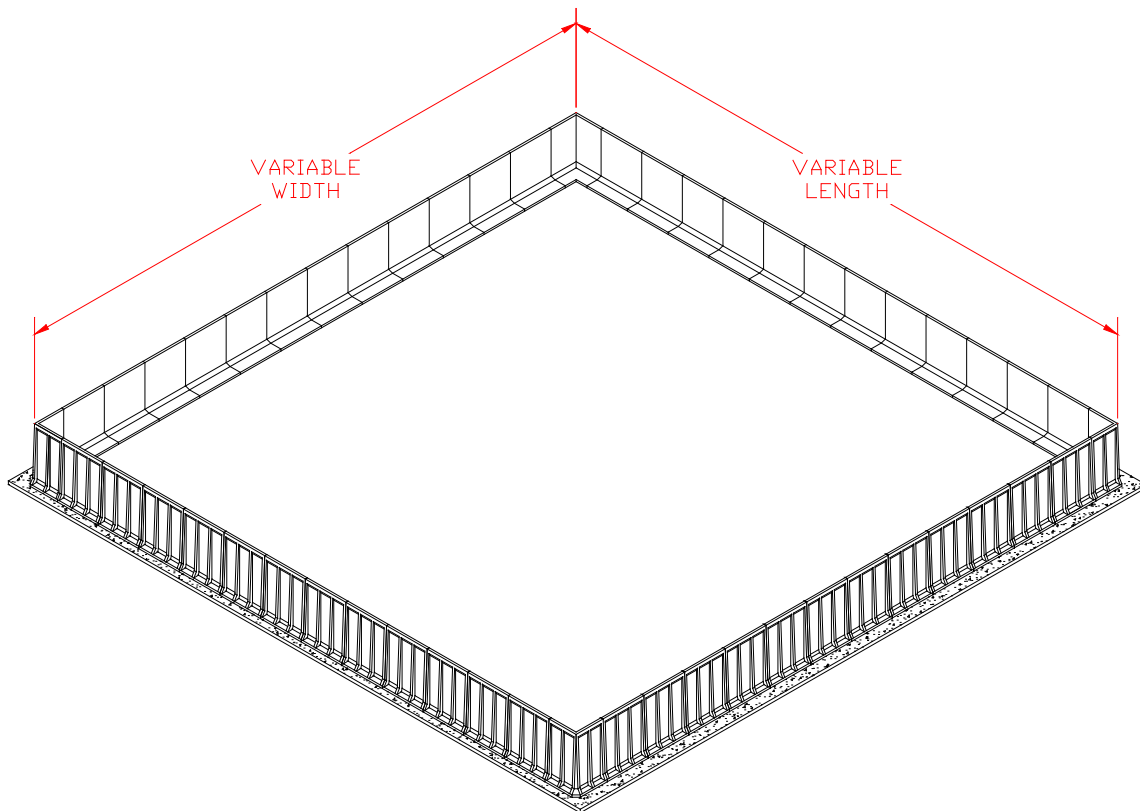



✓ Moveable

✓ Durable



✓ Versatile

✓ Expandable

